

**Model AN10**

**Anemometer**

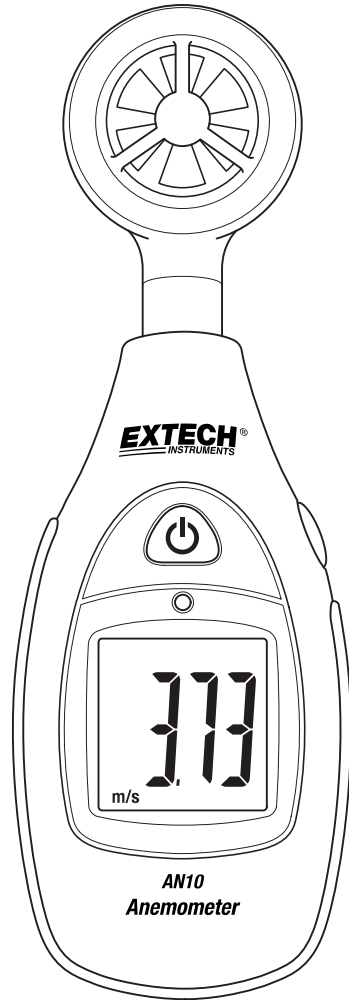

## ***Introduction***

---

Congratulations on your purchase of the Extech Anemometer the AN10. This device measures air velocity via the attached mini-vane sensor in units of m/s, fpm, mph, kph, and knots. The large, easy-to-read backlit LCD displays measurement readings and status indicators. This device is shipped fully tested and calibrated and, with proper use, will provide years of reliable service. Please visit our website ([www.extech.com](http://www.extech.com)) to check for the latest version of this User Guide, Product Updates, and Customer Support.

## ***Safety***

---

- The probe extending from the top of the meter houses the sensitive air velocity vane sensor, do not mishandle, shock, or allow liquids to come into contact with it.
- The probe sensor can cause personal injury if it is misused or mishandled. Use caution when handling this device.
- Do not allow children to handle this device or the accessories and packing materials supplied with it.
- The meter uses a 9V battery (installed in the rear battery compartment). Please remove the battery from the meter if the meter is not to be used for a long period of time. Spent batteries that remain in the meter could potentially leak and cause damage to the meter.

## Meter Description

---

1. Air Velocity vane sensor
2. Power ON/OFF button
3. Backlight ambient light sensor
4. Air Velocity reading on LCD
5. Unit of measure
6. MAX-AVG button (also used to change units)

Note: Threaded Tripod mount and Battery Compartment are located on rear of meter (not pictured)

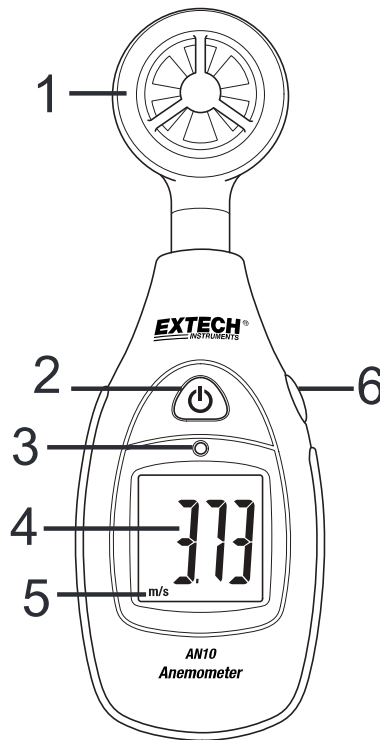

## Display Layout

---

1. Units of measure
2. Air Velocity reading
3. Low Battery symbol
4. Maximum air velocity measurement
5. Average air velocity measurement

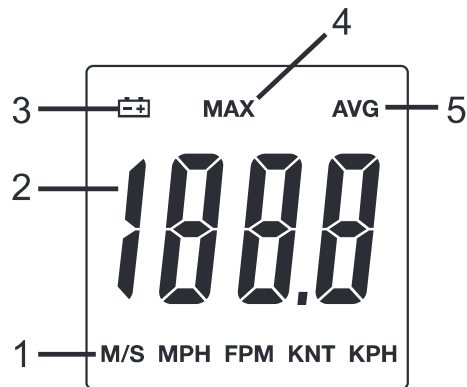

# Operation

---

## Power

Press the Power  button to switch the meter ON or OFF. If the meter does not switch ON when prompted, check that a fresh 9V battery is installed correctly in the rear battery compartment.

## Air Velocity Measurements

1. Switch the meter ON using the power button.
2. Hold the probe so that the air enters the vane from the rear of the meter.
3. Read the air velocity measurements on the LCD.

## Units selection

1. Switch the meter ON.
2. Press and hold the MAX-AVG button for 2 seconds.
3. The unit of measure will step to the next unit of measure on the list below
4. Repeat step 3 until the desired unit of measure is selected.

### Units of Measure List

M/S: meters per second

MPH: miles per hour

FPM: feet per minute

KNT: knots (nautical miles per hour)

KPH: kilometers per hour

## MAX-AVG Recording

1. Press the MAX-AVG button momentarily to display the highest air velocity reading (maximum) recorded. The reading shown will be the highest reading measured since the meter was switched ON. The MAX icon will appear at the top of the LCD.
2. Press the MAX-AVG button again to display the average of all air velocity readings (AVG) taken since the meter was switched ON. The AVG icon will appear at the top of the LCD.
3. Press the MAX-AVG button again to switch the display back to real time measurement mode. The MAX and AVG icons will switch OFF.
4. To reset the record history, switch the meter OFF then back ON again.

## LCD Backlight

The LCD backlight switches ON automatically when the ambient light dims below the threshold. The ambient light sensor is located directly above the LCD window. To test the backlight, cover the ambient light sensor and the LCD backlight should immediately switch ON.

## Maintenance

---

### Cleaning and storage

1. Meter housing only: Clean with a damp cloth and mild detergent when necessary. Do not use solvents or abrasives.
2. Do not attempt to introduce liquid into the vane area when cleaning.
3. Store the meter in an area with moderate temperature and humidity.

### Battery Replacement

The battery symbol appears on the LCD when the 9V battery needs to be replaced.

Replace the 9V battery as follows:

1. Switch the meter OFF if necessary.
2. Remove the rear battery compartment cover by sliding the compartment cover downward.
3. Replace the 9V battery carefully.
4. Situate and stow the red and black wires over the top of the battery so that the battery can fit correctly and so that the compartment can close correctly. Use caution to avoid crimping the wires when closing the compartment cover.
5. Always re-assemble the meter before operating.



Never dispose of used batteries or rechargeable batteries in household waste. As consumers, users are legally required to take used batteries to appropriate collection sites, the retail store where the batteries were purchased, or wherever batteries are sold.

**Disposal:** Do not dispose of this instrument in household waste. The user is obligated to take end-of-life devices to a designated collection point for the disposal of electrical and electronic equipment.

#### Other Battery Safety Reminders

- Never dispose of batteries in a fire. Batteries may explode or leak.
- Never mix battery types. Always install new batteries of the same type.

**WARNING:** To avoid electric shock, do not operate the meter until the battery cover is in place and fastened securely.

## Specifications

---

Measurement Function	Range and Resolution	Accuracy (of reading)
m/s (meters per second)	1.1 to 20	+/- (3% + 0.30 m/s)
fpm (feet per minute)	80 to 3936	+/- (3% + 40 ft/m)
mph (miles per hour)	0.9 to 45	+/- (3% + 0.4 mph)
kph (kilometers per hour)	0.8 to 72	+/- (3% + 1.0 km/hr)
Knots	0.8 to 39	+/- (3% + 0.4 knots)

<b>Display</b>	Backlit LCD with status indicators
<b>Sensor Type</b>	Multi-arm vane with frictionless ball bearing mechanism
Auto Power off	Auto shut off after 15 minutes
<b>Accuracy note</b>	Accuracy is specified for the following ambient temperature range: 18 to 28°C (64 to 82°F)
<b>Sampling Rate</b>	1 sample per second
<b>Operating Conditions</b>	0 to 50°C (32 to 122°F); < 80% RH non-condensing
<b>Storage Conditions</b>	-10 to 60°C (14 to 140°F); <80% RH non-condensing
<b>Power Supply</b>	9V Battery
<b>Battery Life</b>	Approx. 100 hours
<b>Dimensions / Weight</b>	135 x 229 x 46mm (5.3 x 9 x 1.8"); 200g (7.0 oz.)

**Copyright © 2013 - 2015 FLIR Systems, Inc.**

All rights reserved including the right of reproduction in whole or in part in any form

**[www.extech.com](http://www.extech.com)**