

3-in-1 Humidity, Temperature and Airflow Meter

Model 45160

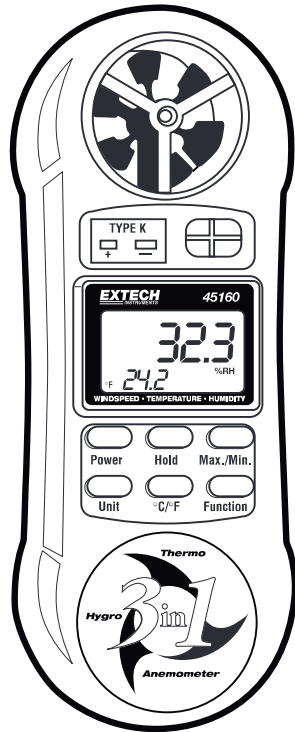

## Introduction

---

Congratulations on your purchase of the Extech Model 45160 3-in-1 Humidity, Temperature and Airflow Meter. The dual display indicates Air Velocity and Temperature or Humidity and Temperature.

This device is shipped fully tested and calibrated and, with proper use, will provide years of reliable service. Please visit our website ([www.extech.com](http://www.extech.com)) to check for the latest version of this User Manual, Product Updates, Product Registration, and Customer Support.

## Specifications

---

### Range Specifications

Measurement	Range	Resolution	Accuracy
MPH (Miles per hour)	0.9 to 67.0MPH	0.1MPH	≤ 3937 ft/min: ±3% F.S. > 3937 ft/min: ±4% F.S
km/hr (kilometers per hour)	1.4 to 108.0 km/h	0.1km/h	
Knots (nautical miles per hour)	0.8 to 58.3 knots	0.1knots	
m/sec (meters per second)	0.40 to 30.00 m/s	0.1 m/s	
ft/min (feet per minute)	80 to 5910 ft/min	1ft/min	
Temperature/Thermistor	32 to 122°F (0 to 50°C)	0.1°F/C	± 2.5°F (± 1.2°C)
Temperature /Thermocouple	-148 to 2372°F	0.1°F	± (1% + 2°F)
	-100 to 1300°C	0.1°C	± (1% + 1°C)
Relative Humidity	10.0 to 95.0%	0.1%	±4% RH (from 10% to 70%RH) ±5.2% RH (> 70% RH)

### General Specifications

Display	4 digit (9999 count) Dual Display LCD
Sensors	Thin film capacitance humidity sensor
Min/Max	Min/Max recalls the highest/lowest reading
Data Hold	Data Hold freezes the display
Operating conditions	0 to 50°C (32 to 122°F) / < 80% RH
Power supply	9 Volt Battery
Dimensions / Weight	Instrument: 156 x 60 x 33mm (6.14 x 2.36 x 1.29") Vane: 24mm (1") diameter / 95 g (3 oz.)

## Meter Description

---

1. LCD display
2. Keypad
3. Vane
4. Thermocouple input jack
5. %RH sensor
6. Battery compartment (rear)

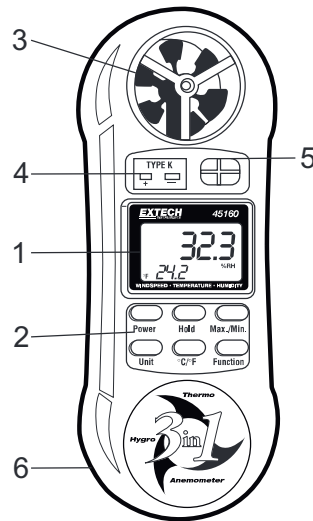

## Operation

---

### Turn Power ON

Press the power button to turn power on. The meter will perform a short self-test.

#### A. Airflow Measurements

1. Press the **Function** button to select the Anemometer function. In Air Flow mode, the display will show Air Velocity and Temperature.
2. Press **Unit** button to select desired unit of measure (FPM, MPH, KNOT, KM/H, or M/S)

#### B. %RH Measurements

1. Press the **Function** button to select %RH function. In %RH mode, the display will show %RH and Temperature.
2. Press the **°C/°F** button to select the desired temperature unit of measure.

#### C. Temperature Measurements

1. Press the **Function** button to select the Temperature function. In Temperature mode, the display will show only temperature.
2. Plug the thermocouple into the meter's thermocouple input jack. If no thermocouple is connected, or if the thermocouple is defective, the meter will display '-----'. (Primary display temperature will only work if a thermocouple is connected).

### MIN, MAX, Recording Function

Press the **Max/Min** button to begin capturing the Minimum (MN), and Maximum (MX), values. Press **Max/Min** to view maximum and minimum recorded readings, Press and Hold the **Max/Min** button until the display returns to standard operation to exit the Max/Min function.

### Data Hold

Press the **HOLD** button to freeze the reading in the display. The 'HOLD' icon will appear on the upper right-hand side of the display. Press the HOLD button again to return to normal operation (the 'HOLD' hold icon will disappear).

### Auto Power OFF

The meter will automatically turn off after 10 minutes if no keys are pressed during this period. Auto power off is disabled in the max/min recording mode.

### Turning Power OFF

Press the power button to turn power off.



As consumers, users are legally required to take used batteries to appropriate collection sites, the retail store where the batteries were purchased, or wherever batteries are sold. **Disposal:** Do not dispose of this instrument in household waste. The user is obligated to take end-of-life devices to a designated collection point for the disposal of electrical and electronic equipment.

## Useful Equations

---

### Area equations



$$A = W * H$$



$$A = \pi * R^2$$

### Cubic equations

$$\text{CFM (ft}^3/\text{min)} = \text{Air Velocity (ft/min)} \times \text{Area (ft}^2\text{)}$$

$$\text{CMM (m}^3/\text{min)} = \text{Air Velocity (m/sec)} \times \text{Area (m}^2\text{)} \times 60$$

**Copyright © 2013-2016 FLIR Systems, Inc.**

All rights reserved including the right of reproduction in whole or in part in any form

**[www.extech.com](http://www.extech.com)**