

User's Guide

EXTECH[®]
INSTRUMENTS
A FLIR COMPANY

Wireless AC Circuit Identifier

Models RT30

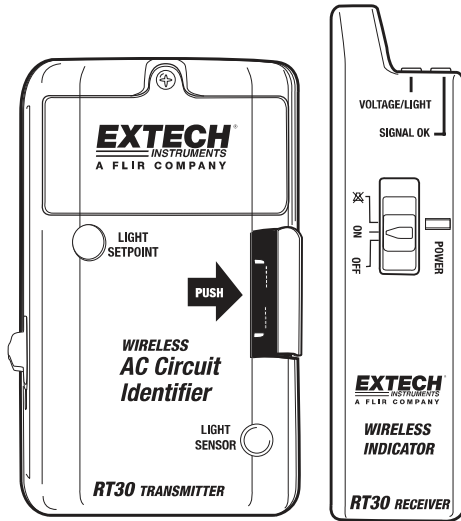

Introduction

Congratulations on your purchase of Extech's Model RT30 (914Mhz) Wireless AC Circuit Identifier. The detector can identify live circuits and detect changes in light level with the wireless receiver. With careful use, this detector will provide years of reliable service.

Meter Description

TRANSMITTER DESCRIPTION

1. Wire clamp slot
2. Wire Clamp release latch
3. Light sensor
4. Voltage/Light detect LED
5. Battery compartment
6. Power LED
7. Light setpoint button
8. Power/Mode select switch
9. External Probe Connector

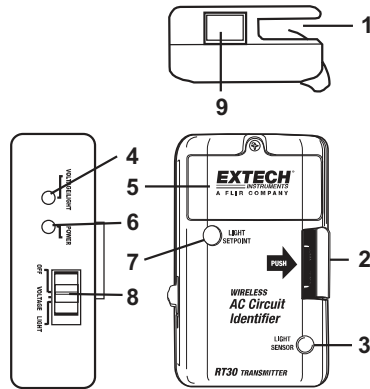

RECEIVER DESCRIPTION

1. Detect LED (Amber)
2. Communication LED (Yellow)
3. Power/Mode
4. Power LED (Green)
5. Battery compartment
6. Pocket clip
7. Audio Buzzer

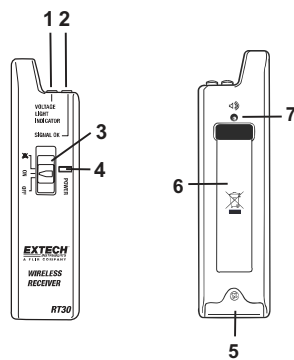

Operation

Detecting Live Circuits (VOLTAGE method)

The RT30 can be directly clamped on installed building wiring and will detect the voltage applied to the wiring.

1. Slide the transmitter power switch to the VOLTAGE position. The POWER LED will switch on.
2. Slide the Receiver power switch to the ON position. The POWER LED and the SIGNAL OK LED will switch ON.
3. Place the Romex™/nm cable (AC wire) directly into the wire clamp slot or, alternatively, connect the external voltage detector probe into the external probe socket and then clamp the probe to any cable, extension cord or appliance cord.
4. If the cable is “live” (voltage present), the VOLTAGE/LIGHT amber LED on the transmitter will switch on and the DETECT LED on the receiver will switch on.
5. If desired, switch the receiver power switch to the audio OFF position  to disable the audible tone.
6. When the voltage is removed (by opening the splice or the circuit breaker, for example), the Detect LEDs will switch OFF and the detect beeper will switch OFF.

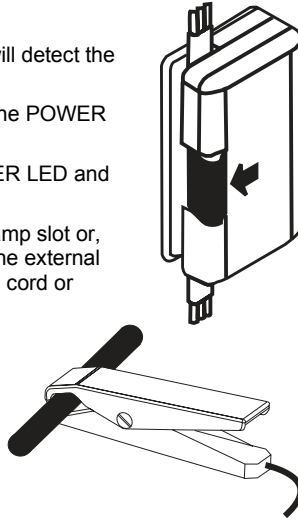

Note: Use of the External Probe overrides the setting of the Power/Mode Switch. The Lighting method cannot be used while the External Probe is attached.

Detecting Live Circuits (LIGHTING method)

In situations where access to circuit wiring is limited, the RT30 can also detect room lighting changes (ON to OFF).

1. Slide the transmitter power switch to the LIGHT position. The POWER LED will switch on.
2. Slide the Receiver power switch to the ON position. The POWER LED will switch on.
3. Cover the Light Sensor on the transmitter and press the Light Setpoint button.
4. Expose the Light Sensor to the light source. The VOLTAGE/LIGHT LED on the transmitter and the DETECT LED on the receiver will switch on.
5. When the lights are turned off the VOLTAGE/LIGHT LED on the transmitter and the DETECT LED on the receiver will switch off, indicating the light has been switched off and power has been removed.

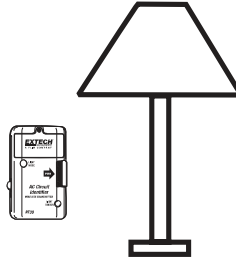

Note: Before use, always test the light on/off operation for proper sensitivity and detection.

Specifications

	Transmitter Unit	Receiver Unit
Indicators	LED	Audio Beeper, LED
Transmission Frequency	RT30 (914MHz)	n/a
Transmission Distance	Approx. 100m (328') in an unobstructed field	
Transmission Power	+10dBm	n/a
Alarm Status	Visual	Visual and audible
Power Supply	Two (2) 'AAA' batteries	Two (2) 'AAA' batteries
Battery Life	80 hours (approximately)	
Operating Temperature	-10 to 50°C (14 to 122°F)	
Storage Temperature	-30 to 60°C (-14 to 140°F)	
Operating Humidity	90% RH from -10 to 30°C (32-86°F) 75% RH from 30 to 40°C (86-104°F) 45% RH from 40 to 50°C (104-122°F)	
Storage Humidity	90% RH max.	
Dimensions	101x61x38mm (4.0x2.4x1.5")	114x30x26mm (4.5x1.17x 1.02")
Weight	0.23 kg (8.0 oz) – three (3) piece total	

Maintenance

Battery Replacement

When the Power LED begins to dim, or the transmitter and receiver stop communicating, the batteries may need to be replaced. Each unit uses two (2) 'AAA' batteries (MN2400 or equivalent). The battery doors can be removed using a Philips screwdriver to loosen the attaching screw.



You, as the end user, are legally bound (**EU Battery ordinance**) to return all used batteries, **disposal in the household garbage is prohibited!** You can hand over your used batteries / accumulators at collection points in your community or wherever batteries / accumulators are sold!

Disposal: Follow the valid legal stipulations in respect of the disposal of the device at the end of its lifecycle

FCC Part 15 (RT30)

This equipment has been tested and found to comply with the limits for a Class B digital device, pursuant to part 15 of the FCC Rules. These limits are designed to provide reasonable protection against harmful interference in a residential installation. This equipment generates, uses and can radiate radio frequency energy and, if not installed and used in accordance with the instructions, may cause harmful interference to radio communications. However, there is no guarantee that interference will not occur in a particular installation. If this equipment does cause harmful interference to radio or television reception, which can be determined by turning the equipment off and on, the user is encouraged to try to correct the interference by one or more of the following measures:

- Reorient or relocate the receiving antenna.
- Increase the separation between the equipment and receiver.
- Connect the equipment into an outlet on a circuit different from that to which the receiver is connected.
- Consult the dealer or an experienced radio/TV technician for help.

Warning: Changes or modifications not expressly approved by the party responsible for compliance could void the user's authority to operate the equipment.

Copyright © 2012 Extech Instruments Corporation (a FLIR company)

All rights reserved including the right of reproduction in whole or in part in any form.
www.extech.com